

Hi-Techno Pump

IWAKI
HI-TECHNO
PUMPS

IX





High turn down ratio

Full motor control varies the discharge and suction speeds independently to provide a full turndown ratio of 750:1.



C150 Capacity
0.2 - 150l/h



C060 Capacity
0.08 - 60l/h



D150 Capacity
0.2 - 150l/h



D300 Capacity
0.4 - 300l/h

Energy savings and Eco-friendly

With the use of helical gears and spring assistance, power consumption is reduced by 70% compared to the standard spring back design.

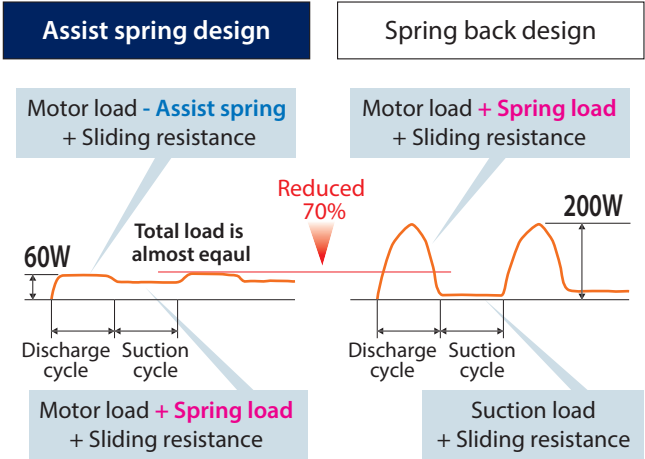

Note: In the case of IX-C type.

A new generation of advanced metering pump technology!

Hi-Techno Pump

IX

Highly precise control offers a solution for every chemical dosing application.

Iwaki's IX Series are digitally controlled direct-drive diaphragm pumps. Years of experience in high-end motor technology result in extremely accurate and energy efficient metering pumps with high resolution. The IX Series meet today's demand for automated chemical delivery in industries from water treatment to chemical process.

Precise chemical dosing operation

The valve design maintains precise dosing at any flow rate whilst the motor regulates discharge and suction speeds to achieve high accuracy (+/-1%) all with a cost effective design from a mechanically driven diaphragm pump.

Efficient pump head design is incorporated with high compression

Fast priming without air locks is achieved with a high compression ratio due to a fixed (maximum) stroke length.

Maximum suction lift:

2m With an open discharge line and dry valve condition.

Degassing ability:

C060: 10 bar, C150: 4 bar

D150: 10 bar, D300: 5 bar

With a standard tubing layout.

Viscous liquid transfer

Standard IX series is capable of pumping liquid viscosities of up to IX-C: 1000mPa·s, IX-D: 300mPa·s. Contact us for higher viscosity applications.

Constant injection with low impact

Flow control via discharge speed adjustment (with a fixed suction speed) assures constant injection at any flow rate. This system also reduces impact (inertia force) and load to the discharge line.

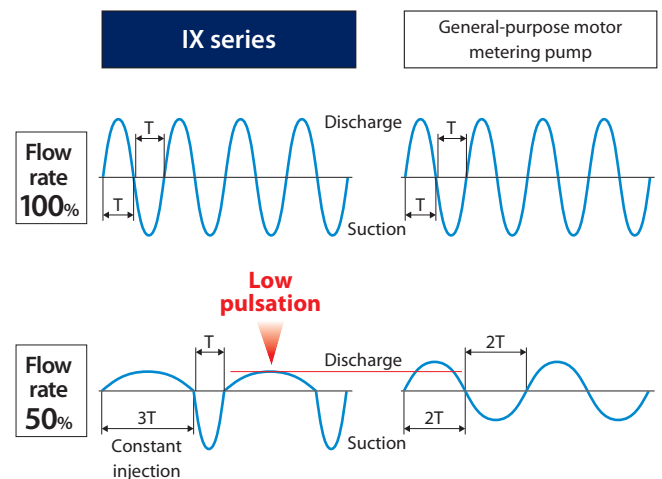

Precise chemical dosing operation and energy savings

Advanced mechanism assists eco-friendliness

Easy operation on a Variety of applications

Safety design

Standard to all models is a diaphragm rupture detector, protecting users and the environment. Also, a detector for abnormal operation protects the pipework in case of an accidental high discharge pressure caused by clogging or improper operation. A drain hole also ensures safe operation even when the diaphragm is damaged.

Note: In some cases it may not be able to detect sudden rises in pressure occurring in shutoff operation. If the piping or machinery in use has low pressure resistance, install a separate safety valve.

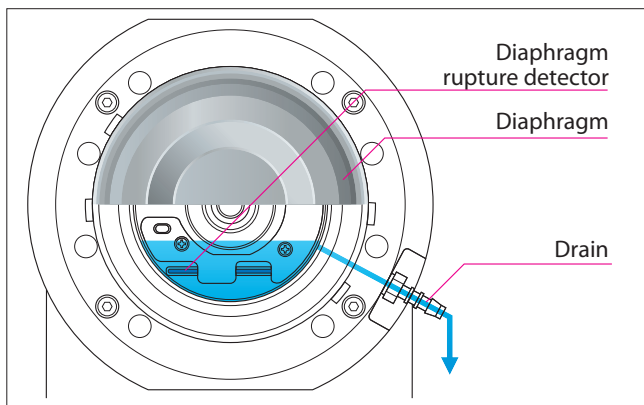

IP65

Drive and control units are sealed separately to an IP65 enclosure.

Compliant to world standards

One of the IX features is multi-voltage operation (100-240VAC) compatible worldwide. Compliant to UL, CE standards.

Cavitation prevention

When pumping viscous liquids, suction stroke speed can be varied to avoid developing cavitation. (Programmable suction speed: 75%, 50% or 25% of the normal speed)

Degassing

Keypad operation or the contact signal (AUX) runs the pump at maximum spm in any mode for degassing.

Calibration

The pump is calibrated prior to shipment, however we recommend recalibration when installed in your system due to pipe layout and liquid properties.

Operation history

Controller memory logs the total power connection time, operating time, number of strokes and number of power-up events.

Maintenance mode

This operation makes it possible to move the diaphragm forward with partial pump stroke operation facilitating diaphragm replacement.

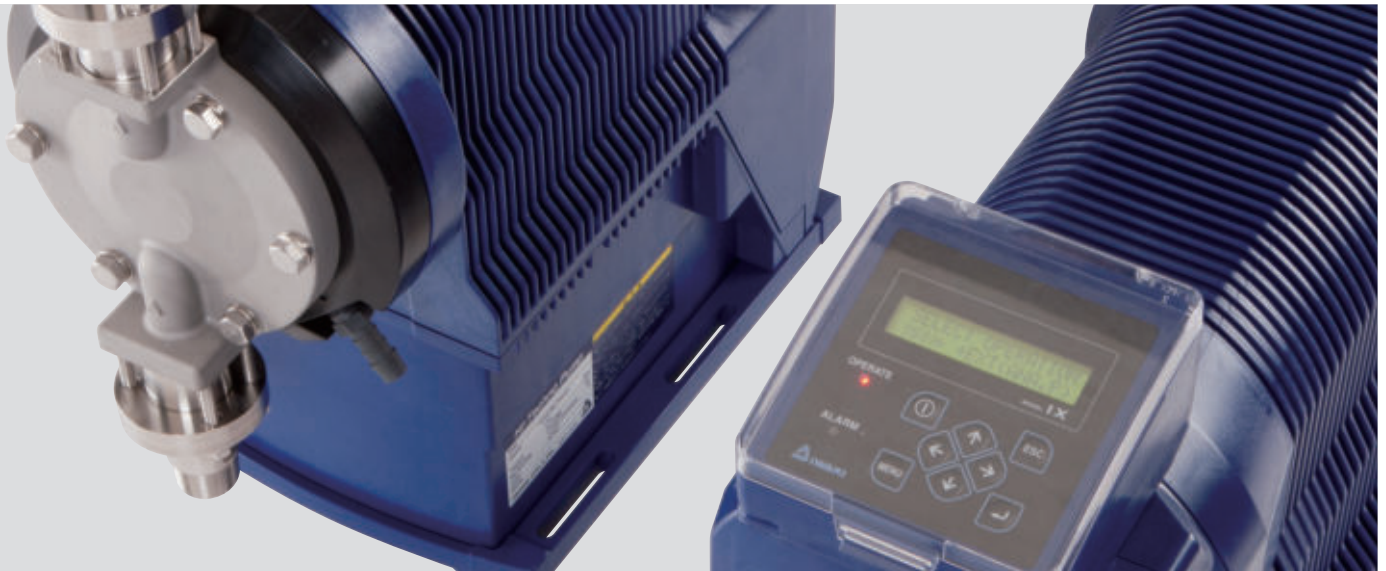

Automatic control

The IX can run in analogue, pulse, batch or interval batch modes.

Analogue operation

The pump operates in response to an input, (4-20mA) from a controller.

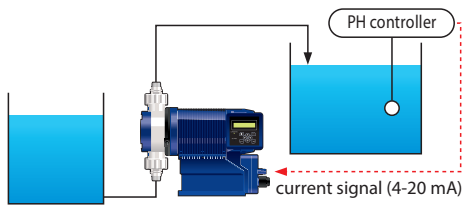

Pulse operation

When combined with a flow meter or contact head water meter, the IX pump gives a paced dose rate in proportion to the main flow rate.

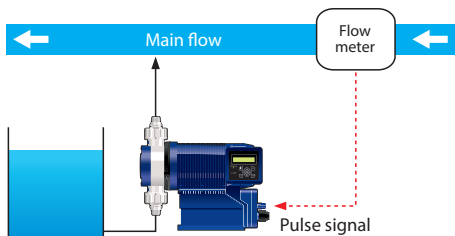

Interval batch operation

Timed operation is possible with simple pump programming via the keypad and is initiated with a pulse signal.

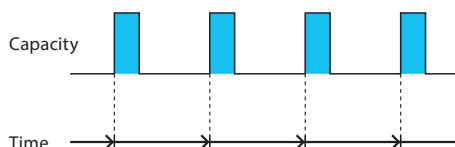

User friendly design

The controller position can be selected from 6 mounting positions for operator convenience. Also, a character LCD with LED backlight and optimized keypad positions assist easy operation.

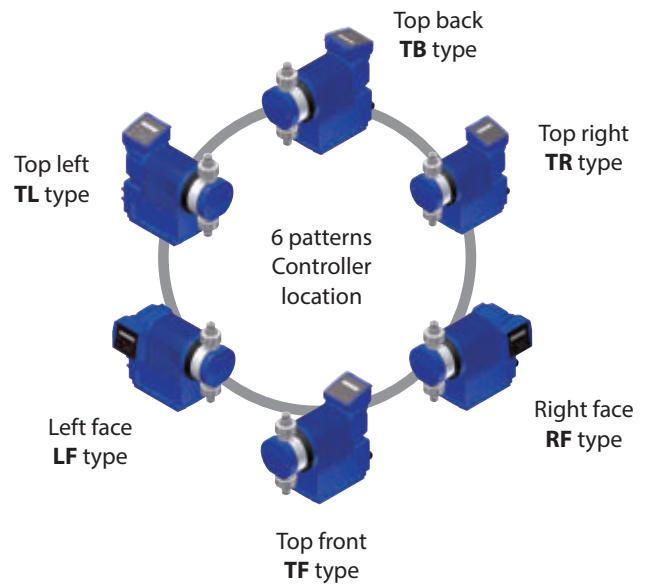

Construction and materials

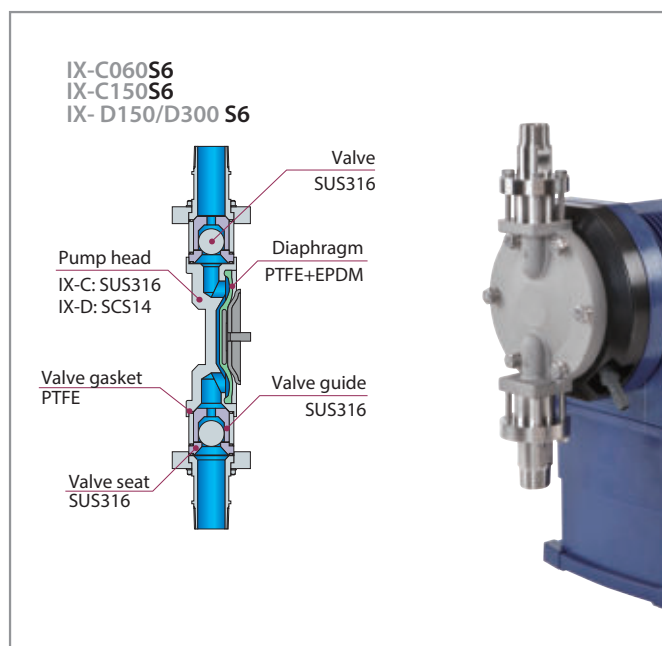
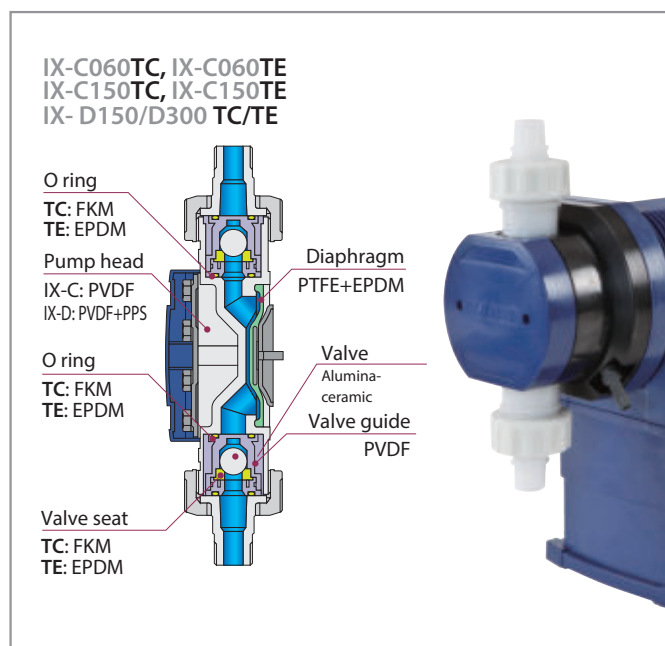

Note: EPDM of PPS and the diaphragm of the pump head is not wetted.

Pump identification

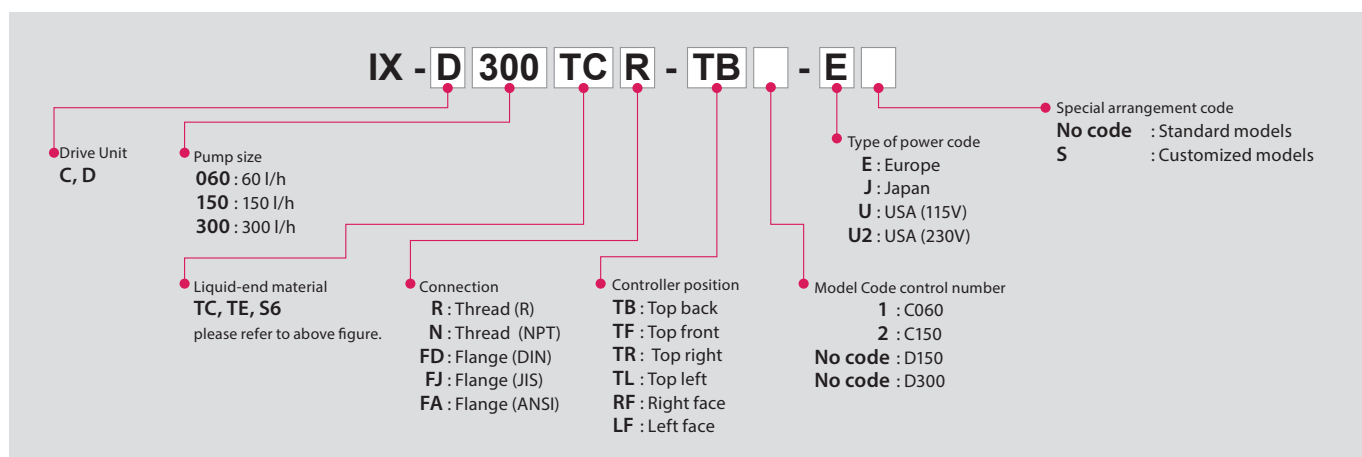

Optional accessories

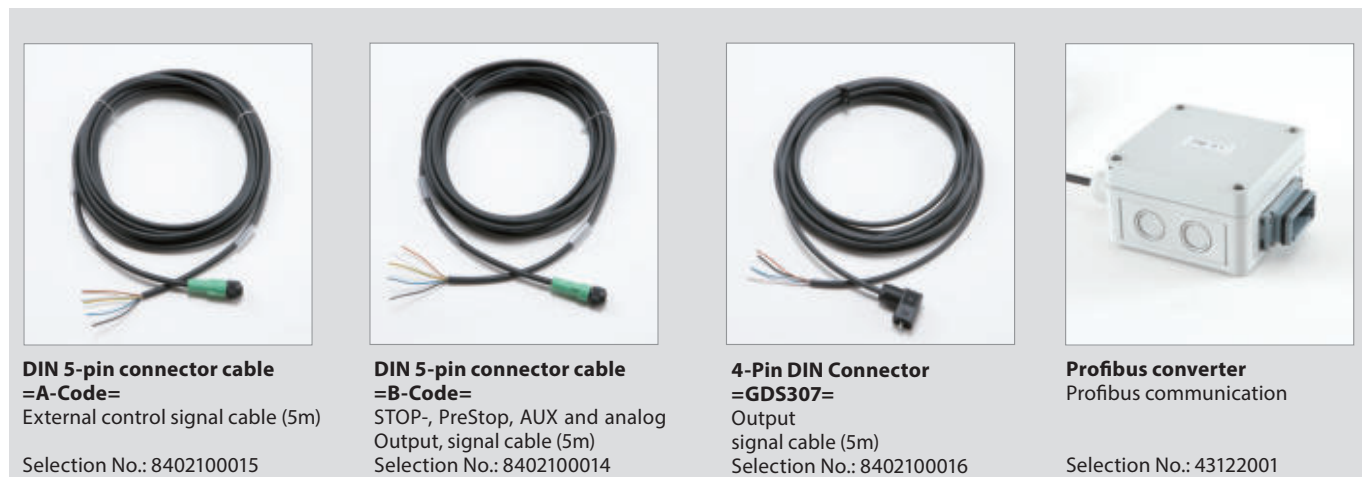

Specifications of pump

Model	Capacity l/h	Max. pressure bar	Max. viscosity mPa·s	Liquid temperature range °C	Connection		Power consumption W	Current A	Mass kg
					Thread	Flange			
IX-C060	0.08 ~ 60	10	1000 ^{Note2}	0 ~ 50	R: R1/2 N: 1/2NPT	FJ: JIS10K15A FD: DIN PN10 DN15 FA: ANSI 150Lb 1/2"	62	0.8	8 (Thread)
				0 ~ 80					9 (Flange)
									10.5 (Thread)
									12 (Flange)
IX-C150	0.2 ~ 150	4	1000 ^{Note2}	0 ~ 50	R: R3/4 N: 3/4NPT	FJ: JIS10K20A FD: DIN PN10 DN20 FA: ANSI 150Lb 3/4"	62	0.8	9
				0 ~ 80					11 (Thread)
									13 (Flange)
									14.5
IX-D150	0.2 ~ 150	10	300 ^{Note2}	0 ~ 50	R: R3/4 N: 3/4NPT	FJ: JIS10K20A FD: DIN PN10 DN20 FA: ANSI 150Lb 3/4"	110	1.3	15 (Thread)
				0 ~ 80					17 (Flange)
									15.5
									17 (Thread)
IX-D300	0.4 ~ 300	5	300 ^{Note2}	0 ~ 50	R: R1 N: 1NPT	FJ: JIS10K 25A FD: DIN PN10 DN25 FA: ANSI 150Lb 1"	110	1.3	15.5
				0 ~ 80 ^{Note3}					17 (Thread)
									19.5 (Flange)
									19.5 (Flange)

• The max. discharge capacity is obtained in operation with clear water at ambient temperature and the max. discharge pressure. It gets higher as the pressure gets lower.
 • Operating temperature range: 0-50 C (Indoor use only) • Operating humidity range: 30-90%RH (Non condensing in the controller) • Contact us for other plumbing connections
 Note 1: For the IX-C060S6, accuracy is not guaranteed at flows below 0.4 L/h. For the IX-C/D150S6, accuracy is not guaranteed at flows below 1.5 L/h. For the IX-D300S6, accuracy is not guaranteed at flows below 3.0 L/h.
 Note 2: The discharge rate may be reduced when pumping viscous liquids. Some allowance should be given when selecting pumps for these applications.
 Note 3: No viscosity change, Non freezing, No slurry.

Controller Specifications

Operation mode	MAN (Manual)	Use the UP and DOWN keys to set a flow rate.		
	EXT	Analog fixed operation	4-20, 0-20, 20-4, 20-0 mA (Proportional to the discharge rate)	
		Analog variable operation	Programmable 2-point setting (Input signal DC 0-20 mA, proportional to the discharge rate)	
		Pulse control ^{Note1}	0.00625ml/PLS - 120mL/PLS (C060)	0.01560ml/PLS - 300mL/PLS (C150)
			0.01560ml/PLS - 300mL/PLS (D150)	0.03120ml/PLS - 600mL/PLS (D300)
		Batch control ^{Note1}	6.25ml/PLS - 120l/PLS (C060)	15.6ml/PLS - 300l/PLS (C150)
			15.6ml/PLS - 300l/PLS (D150)	31.2ml/PLS - 600l/PLS (D300)
Interval batch control ^{Note1}	Day: 0 - 9, Hour: 0 - 23, Minute: 1 - 59 6.25ml - 120l (C060), 15.6ml - 300l/PLS (C150), 15.6ml - 300l (D150), 31.2ml - 600l/PLS (D300)			
Profibus control	Communication protocol: Profibus-DP-compliant international standard: EN50170 (IEC61158)			
Monitors	LCD	16 digits x 2 lines, backlit character LCD		
	LED	OPERATE	Lights in green colour during pump operation.	
			Lights in orange colour when a Pre-Stop signal is input.	
			Lights in red colour when the pump has stopped or flashes when overload is detected.	
	ALARM	Red: Lights up when Alarm1 or Alarm2 is output		
Operation	Keypads	Start/Stop, MENU, ESC, Enter, Up, Down, Left and Right keys		
Control function	STOP	Operation stops with input contact ^{Note2}		
	PRIME	Max spm operation by pressing the UP and DOWN keys		
	Keylock	Password setting to lock and release operation keys		
	Interlock	Operation stops with input contact ^{Note2}		
	AUX	Pump operates at the set discharge rate with input contact.		
	Maximum discharge rate	Arbitrarily set the upper discharge limit in each operation mode.		
	Buffer memory function	Store the number of pulses entered in batch operation.		
	Analog input value display	Display the analog input value.		
Input	STOP/Pre-Stop	No-voltage contact or open collector ^{Note3}		
	AUX	No-voltage contact or open collector ^{Note3}		
	Interlock	No-voltage contact or open collector ^{Note3}		
	Analogue	0 - 20mADC (Internal resistance is 200ohm.)		
	Pulse	No-voltage contact or open collector Max pulse frequency is 100Hz.		
Output	Alarm1 (OUT1)	Non-voltage contact (mechanical relay): AC 250 V, 3 A (resistive load)		
		Each output item is selected by Enable/Disable. Batch complete ^{Note4} /STOP/Pre-Stop/Interlock/Leak Detection/Motor Overload/Drive Error		
	Alarm2 (OUT2)	Non-voltage contact (photo relay): AC/DC 24 V, 0.1 A (resistive load)		
		Each output item is selected by Enable/Disable. Volume Prop. PLS ^{Note5} /Batch complete ^{Note4} /STOP/Pre-Stop/Interlock/Leak Detection/Motor Overload/Drive Error		
External power supply	DC 12 V, 30 m A or less			
Current	DC 0-20 mA, Two-point setting (allowable load resistance: 300 Ω)			
Power voltage ^{Note6}	100-240VAC 50/60Hz			

Note 1: The minimum settings for pulse operation, batch operation, and interval batch operation are the flow rates per stroke corrected by calibration.

Also, the change rate of the setting value per pulse is the flow rates per stroke corrected by calibration.

Note 2: Switches to pump operation with input contact if default state is changed in the controller settings.

Note 3: The maximum voltage and current applied to the contact are 12 V and 5 mA. If you use a contact such as a relay, the minimum applicable load must be 5 mA or less.

Note 4: When Batch Complete (batch operation complete output) is set to Enable, the other functions will be set to Disable.

Note 5: When Volume Prop. PLS output is set to Enable, the other functions will be set to Disable.

Note 6: Do not apply voltage out of the specified range. Doing so may cause malfunction or failure. The allowable voltage supply range is 90-264VAC only.

Dimensions (mm)



IX-C

IX-C150TC, IX-C150TE

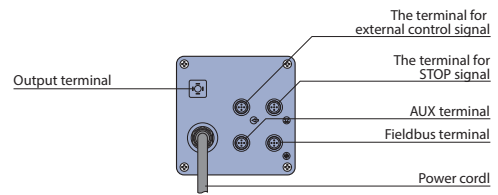
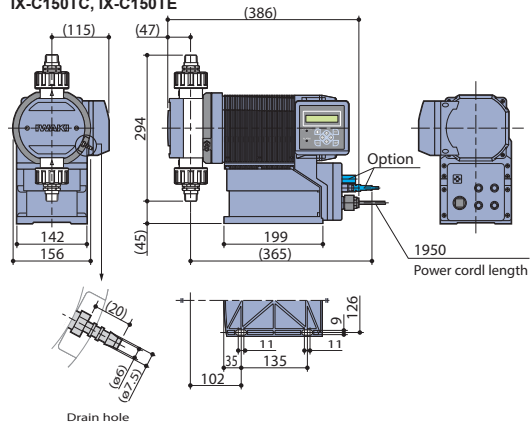

IX-C150TC, IX-C150TE

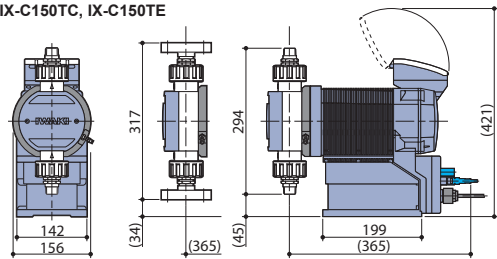

IX-C060TC, IX-C060TE

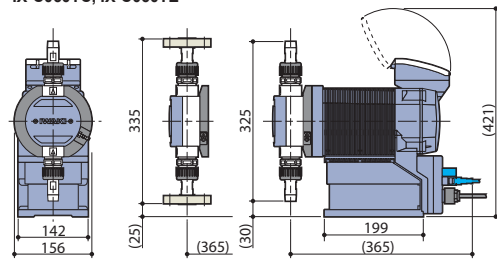

IX-C150S6

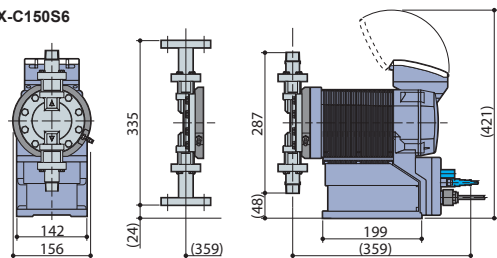

IX-C060S6

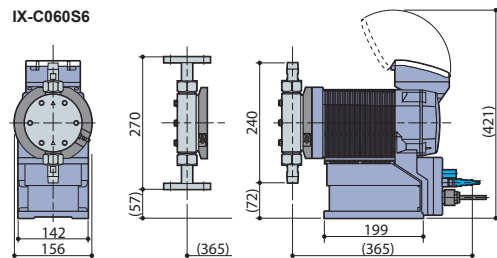

IX-D

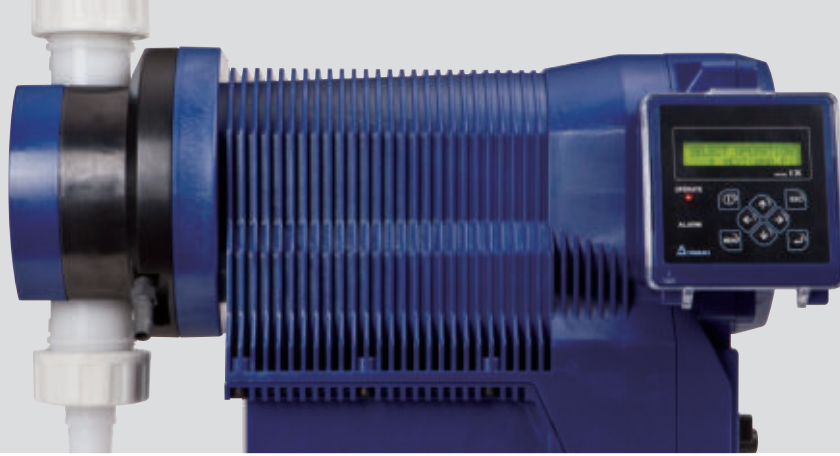

IX- (D150/D300) (TC/TE) R - TB

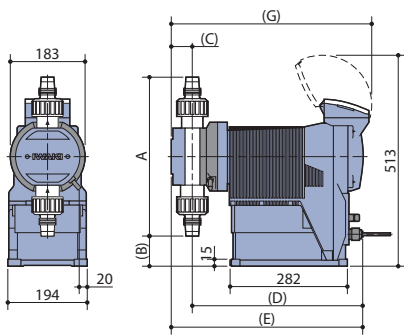

IX- (D150/D300) (TC/TE) R - RF

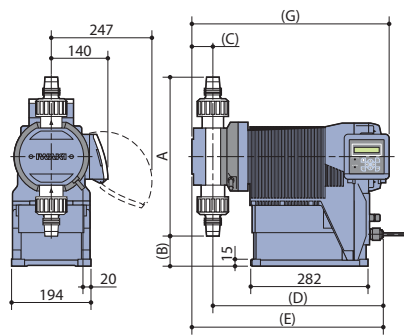

IX- (D150/D300) (TC/TE) FJ - TB

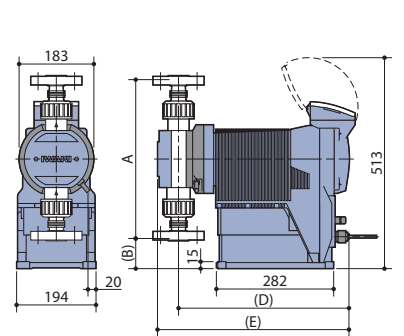

IX- (D150/D300) (TC/TE) FJ - RF

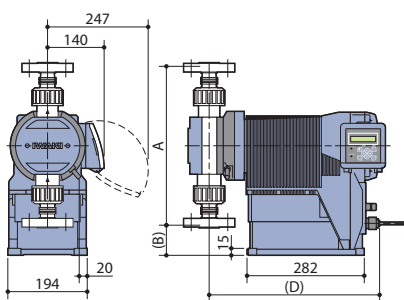

IX- (D150/D300) S6R - TB

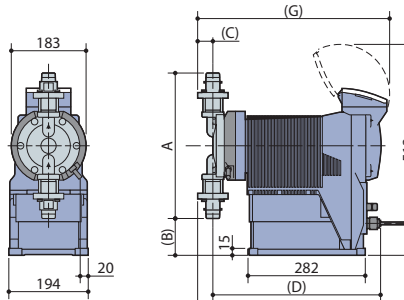

IX- (D150/D300) S6R - RF

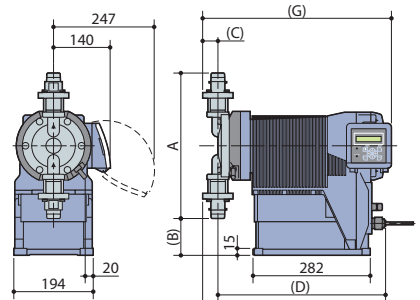

IX- (D150/D300) S6FJ - TB

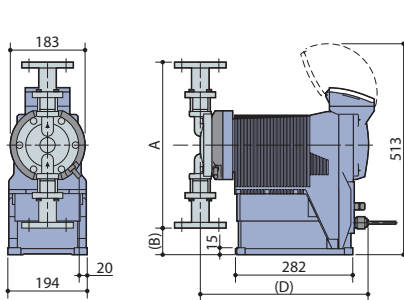

IX- (D150/D300) S6FJ - RF

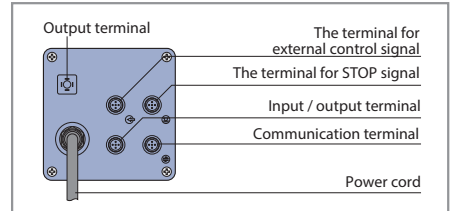
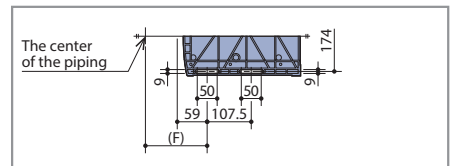
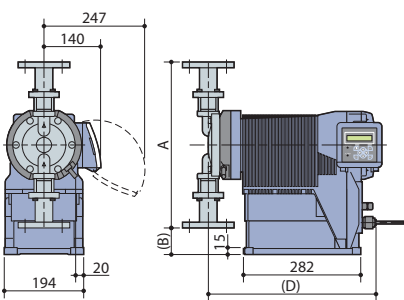

Model	A	B	C	D	E	F	G
IX-D150 TC R-RF	317	108	42	409	450	144	465
IX-D300 TE R-RF	384	74	52	415	467	151	482
IX-D150 TC R-TB	317	108	42	409	450	144	472
IX-D300 TE R-TB	384	74	52	415	467	151	489
IX-D150 TC FJ-RF	340	97	-	409	-	144	-
IX-D300 TE FJ-RF	383	66	-	415	-	151	-
IX-D150 TC FJ-TB	340	97	-	409	-	144	-
IX-D300 TE FJ-TB	383	66	-	415	-	151	-

Model	A	B	C	D	E	F	G
IX-D150 S6 R-RF	315	108	30	401	431	136	453
IX-D300 S6 R-RF	355	88	37	408	445	143	460
IX-D150 S6 R-TB	315	108	30	401	431	136	460
IX-D300 S6 R-TB	355	88	37	408	445	143	467
IX-D150 S6 FJ-RF	363	84	-	401	-	136	-
IX-D300 S6 FJ-RF	405	63	-	408	-	143	-
IX-D150 S6 FJ-TB	363	84	-	401	-	136	-
IX-D300 S6 FJ-TB	405	63	-	408	-	143	-

Points to be observed in pump installation and piping

IX Series Hi-Techno pumps are positive-displacement, reciprocating pumps. Reciprocating pumps generate pulsation in the suction and discharge piping. Special consideration, (different from the ordinary centrifugal pumps), should be given to this point when planning the pump installation and piping.

• Prevention of pipe vibration

Discharge side inertial resistance $P_{id} < 0.1$ MPa
 • P_{id} : Inertial resistance on discharge side

Inertial resistance means the pulsated impact force generated by the flow just upon entering discharge stroke. It is a phenomenon particular to a reciprocating pump which is generated as a result of the sudden application of acceleration to the liquid in the discharge piping. The condition " $P_{id} < 0.1$ MPa is given above as an approximate standard. If P_{id} becomes 0.1MPa or higher, vibration on the pipe is generated. So measures should be taken to cope with the influence of vibration on the pump, too.

Measures
 1. Install pulsation prevention device (air chamber).
 2. Enlarge the diameter and shorten the length of the discharge piping.

• Prevention of overfeeding

Pump differential pressure > Inertial resistance P_i
 • The larger one of the suction side or the discharge side

Overfeeding means excessive flow of the liquid due to abnormal functioning of the check valve caused by pulsation of the liquid in the piping. Check carefully in case the differential pressure is low and in case the piping is too long even with the differential pressure value at 0.03 MPa.

Measures
 1. Install air chamber.
 2. Install back pressure valve

• Prevention of suction failure

$NPSH_a > NPSH_r$
 $NPSH_a = P_a - P_v \pm P_{hs} - P_{is} * MPa$
 *Or P_{fs} : whichever is the larger. (NPSH : Net positive suction head)

If $NPSH_a$ is not sufficient, the pump may be damaged by the flow-break or cavitation generated under such conditions.

- **NPSH_a**: Absolute NPSH (MPa)
- **NPSH_r**: Required NPSH (value particular to the pump) (MPa)
- **P_a**: Absolute pressure onto the tank liquid surface (MPa)
- **P_v**: Liquid vapour pressure (MPa)
- **P_{hs}**: Pressure caused by the height of the suction side (MPa) (Flooded suction : +, Negative suction : -)
- **P_{is}**: Inertial resistance on the suction side (MPa)
- **P_{fs}**: Piping resistance on the suction side (MPa)

See the table below for $NPSH_r$, inertia resistance(P_i) and applicable chambers.

 Compressed air dissolves in solutions in a chamber. Supply air into the chamber periodically, or its performance may reduce. It takes longer time for air to be compressed enough to deliver liquid as a flow rate gets lower.

• Pump/Piping protection

Install a relief valve to protect the pump and piping from overpressure.

Performance

Model	Discharge line inertia resistance P_{id}		Suction line inertia resistance P_{is}		NPSH _r	Viscosity	Priming lift	Applicable chamber Materials	
	L/hr	MPa/1m	(%)	MPa/1m				SUS	PVC
IX-C060	60	4.4×10^{-3}	100	4.4×10^{-3}	0.08 MPaA	1000 mPa·s	2 m	1.5 L	2.0 L
	45	1.6×10^{-3}	75	2.5×10^{-3}					
	30	4.9×10^{-4}	50	1.1×10^{-3}					
	6	1.2×10^{-5}	25	2.8×10^{-4}					
IX-C/D150	~150	6.3×10^{-3}	100	6.3×10^{-3}	0.08 MPaA	IX-C: 1000 mPa·s IX-D: 300 mPa·s	2 m	IX-C: 1.5 L IX-D: 5.0 L	IX-C: 2.0 L IX-D: 5.0 L
	~113	2.3×10^{-3}	75	3.6×10^{-3}					
	~75	7.0×10^{-4}	50	1.6×10^{-3}					
	~15	1.8×10^{-5}	25	4.0×10^{-4}					
IX-D300	~300	7.2×10^{-3}	100	7.2×10^{-3}	0.08 MPaA	300 mPa·s	2 m	5.0 L	5.0 L
	~225	4.1×10^{-3}	75	4.1×10^{-3}					
	~150	8.0×10^{-4}	50	1.8×10^{-3}					
	~30	2.0×10^{-5}	25	4.5×10^{-4}					

- P_i : Inertia resistance per meter (based on clean water, suction line I.D. should be equal to the pump suction connection as a minimum.)
 Calculate inertia resistance per meter using the following formula.
 $P_i = P_{id} \text{ (or } P_{is}) \times \text{Specific gravity} \times \text{Pipe length (m)} \times (\text{Pump I.D.} \div \text{Pipe I.D.})^2 \text{ (MPa)}$
- Suction speed is set to 100% as the default setting. Reduce speed when handling viscous or gaseous liquids to prevent the possibility of cavitation.
 Note the suction speed is used to control maximum discharge capacity.
 e.g.) If suction speed is set to 75%, maximum discharge capacity is correspondingly reduced to 75% (45L/h for IX-C060, 113 L/h for IX-C150).
- Discharge capacity may be reduced from rated performance when pumping highly viscous liquids. Select a suitable pump size according to liquid viscosity.
 Contact us if handling liquid viscosities of over 1000 mPa·s.(IX-C) Contact us if handling liquid viscosities of over 300 mPa·s.(IX-D)
- Applicable chamber: Capacities are based on Iwaki standard chamber sizes. Contact us for chamber materials.
- High accuracy: $\pm 1\%$ (This accuracy may not be met at flows below 1.0 L/h for the IX-C150S6. For model IX-C060S6, accuracy may not be met at flows below 0.4 L/h)
- Liquid temperature range: 0-50 °C(TC/TE type), 0-80 °C(S6 type) No viscosity change, Non freezing, No slurry
 Accurate calibration may not be possible with liquid temperatures over 60°C and discharge pressures over 0.8MPa. For optimum accuracy, calibration must be performed below these parameters.

Optional accessories / example of piping

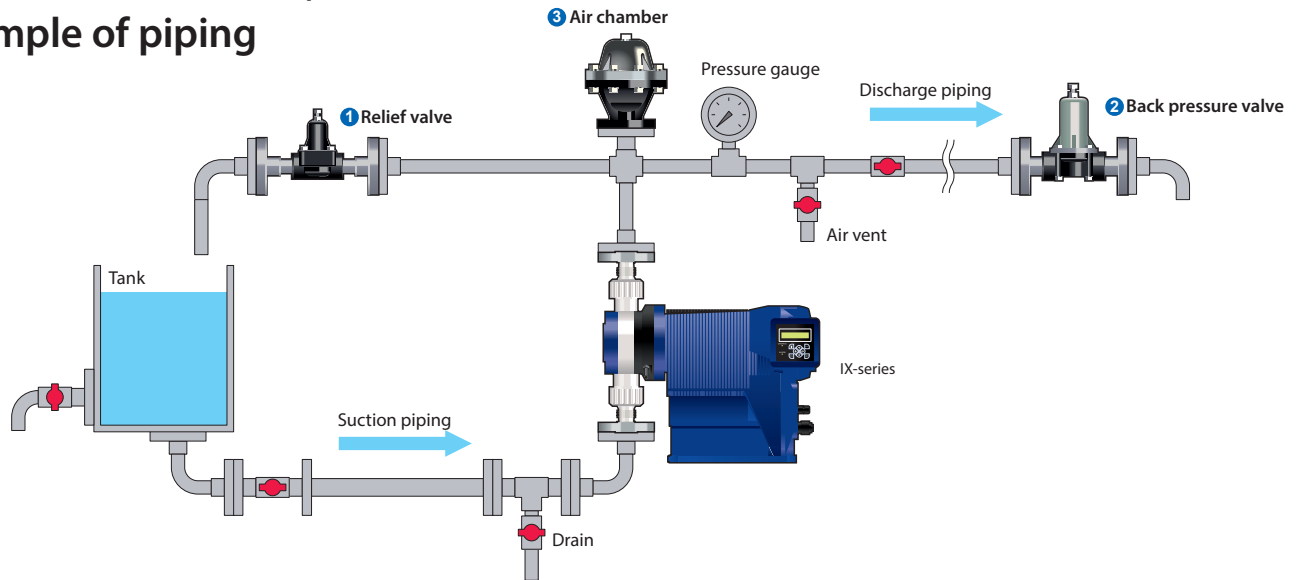

1 Relief valve Model RV

Positive displacement pumps keep operating even in a closed-discharge condition, resulting in piping breakage or pump failure from overpressurization without a relief valve. Always install a relief valve to prevent overpressure in the discharge line.



Model	Wet-end materials		Max. capacity l/min (l/h)	Setting pressure bar	Connection JIS10K Flange	Mass kg
RV-7TV-15	PVDF	PTFE	7.5 (450)	3 ~ 8	15A	5
RV-7TE-15					EPDM	
RV-7TV-25					FKM	
RV-7TE-25					EPDM	
RV-2S6-15	SUS316	PTFE	2.0 (120)	3 ~ 8	15A	3.5
RV-2S6B-15					15A (JIS16K)	
RV-7S6-25	SCS14	PTFE	7.5 (450)	3 ~ 8	25A	6
RV-7S6B-25					25A (JIS16K)	
RV-3P-15	PVC	PTFE	3.0 (180)	3 ~ 10	15A	0.6
RV-3P-20					20A	
RV-3P-25					25A	

2 Back pressure valve Model BV

Install a back pressure valve when discharge-line pressure is less than 0.3 bar or less than suction-line pressure. Pump check valves may otherwise not operate correctly and overfeeding may result. Differential pressure between discharge and suction lines must be 0.3 bar or more and also greater than the inertia resistance (Pid or Pis, whichever greater). Differential pressure (0.3 bar or more) > Inertia resistance (Pid or Pis, whichever is greater)



Model	Wet-end materials		Capacity l/min (l/h)	Setting pressure bar	Connection JIS10K Flange	Mass kg
BV-7TV-15	PVDF	PTFE	0.2 ~ 7.0 (12 ~ 420)	0.5 ~ 8	15A	5
BV-7TE-15					EPDM	
BV-7TV-25					FKM	
BV-7TE-25					EPDM	
BV-2S6-15	SUS316	PTFE	0.02 ~ 2.0 (1.2 ~ 120)	0.5 ~ 8	15A	3.5
RV-7S6-25					25A	
BV-3NV-15	PVC	FKM	0.03 ~ 3.0 (1.8 ~ 180)	1 ~ 3	15A	0.6
BV-3NV-20					20A	
BV-3NV-25					25A	
BV-3NE-15		EPDM			15A	0.6
BV-3NE-20					20A	
BV-3NE-25					25A	

Contact us for use at smaller flow rates than the above.

3 Air chamber Model A

The air chamber reduces flow pulsation to prevent piping vibration and overfeeding. An air chamber designed for slurry transfer is also available. Contact us for detail.



SUS type



PVC type

Model	Wet-end materials	Capacity l	Max. pressure bar	Connection JIS10K Flange	Mass kg
A-1S6-15	SUS316	1.5	9	15A	5
A-1S6-20				20A	
A-1S6-25				25A	
A-2VV	PVC	2.0	5	15 ~ 25A shared	2.5
A-2VE					
A-5S6-25A	SUS316	5	9	25A	12
A-5VV	PVC	5	5	25A	5
A-5VE					

FKM O rings (A-2VV) and EPDM O rings (A-2VE) are not wet end materials. Please contact us for other materials.



<https://www.iwaki.de>

IWAKI Europe GmbH, Siemensring 115, 47877 Willich, Germany
TEL: +49 2154 9254 10 FAX: +49 2154 9254 48 E-Mail: sales@iwaki.de

 **Caution for safety use:**
Before use of pump, read instruction manual carefully to use the product correctly.

Actual pumps may differ from the photos.
Specifications and dimensions are subject to change without prior notice. For further details please contact us.

 **Legal attention related to export.**

Our products and/or parts of products fall in the category of goods contained in control list of international regime for export control.
Please be reminded that export license could be required when products are exported due to export control regulations of countries.

The posting and copying from this catalogue
without permission is not accepted firmly.